

- Tumbles grinding sparks and embers through a torturous path, giving them **time to burn out before exiting**
- **Patented design** where there are **no space requirements** between the spark trap and the dust collector
- Has **proven spark mitigation**, greatly reducing the risk of fire and filter media damage

Applications

- Recommended for most metal dusts



LEGEND

APC

Spark Trap



Features

- Rugged steel construction
- Powder-coated for durability
- Exclusive, patented, ember-snuffing design
- Tool-free clean-out door
- Optional drop-out kit allows for floor-level emptying
- Can be placed right at the collector
- Minimal pressure drop



4" model without reducer shown



Vortex-producing inlet cone



1-year warranty for material defects and workmanship is provided from the date of manufacture for all fabricated items.

us-duct.com | 336-530-1690 | info@us-duct.com

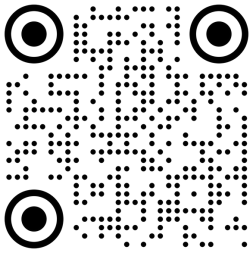

Spark Trap

Technical Data

- Available in 4" to 44" diameter inlets/outlets
- Rolled lip connections on sizes up to 24"
- Flanged connections on sizes above 24"
- Hangers included
- Recommended velocity: 3200 fpm
Pressure Drop: 0.8" at 3200 fpm
Pressure Drop: 2.8" at 4500 fpm

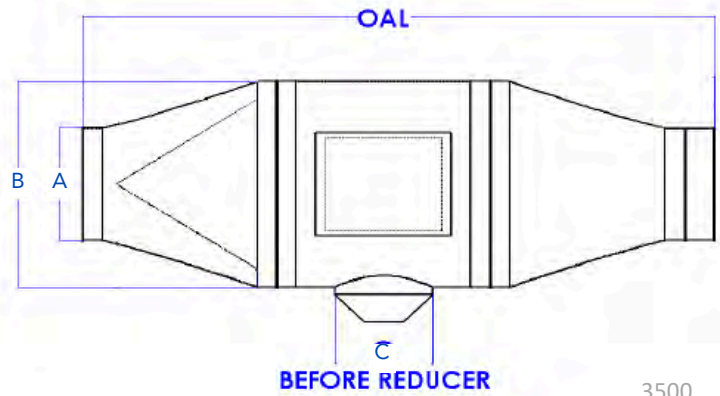

	A	B	C	OAL	
SKU	Inlet	Body	Dropout Diameter	Overall Length***	CFM@ 3500 FPM
LSST04.G	4	8	4	40	305
LSST06.G	6	10	4	40	687
LSST08.G	8	14	6*	48	1222
LSST10.G	10	18	8*	56	1303
LSST12.G	12	22	10**	65	2749
LSST14.G	14	24	10**	68	3742
LSST16.G	16	28	10**	77	4887
LSST18.G	18	32	14**	88	6185
LSST20.G	20	34	14**	90	7636
LSST22.G	22	38	14**	100	9239
LSST24.G	24	42	18**	109	10996
LSST26.G	26	46	18**	117	12905
LSST28.G	28	48	18**	121	14966
LSST30.G	30	52	18**	131	17181
LSST32.G	32	56	18**	140	19548
LSST34.G	34	60	18**	150	22068
LSST36.G	36	62	18**	152	24740
LSST38.G	38	66	18**	161	27565
LSST40.G	40	70	18**	169	30543
LSST42.G	42	74	18**	177	33674
LSST44.G	44	76	18**	179	36957

* Includes Reducer to 4" Hose for Collection Barrel

** Includes Reducer to 6" Hose for Collection Barrel

*** Overall length will vary slightly depending on requested end conditions and variations in sotkc items; +/- 1". Length based on average width of connections at 2".

1-year warranty for material defects and workmanship is provided from the date of manufacture for all fabricated items.